

Before You Use This Machine

**Before you can send or receive fax messages,
please take about 30 minutes to set up your machine.**

Set up your machine as in the following procedures.

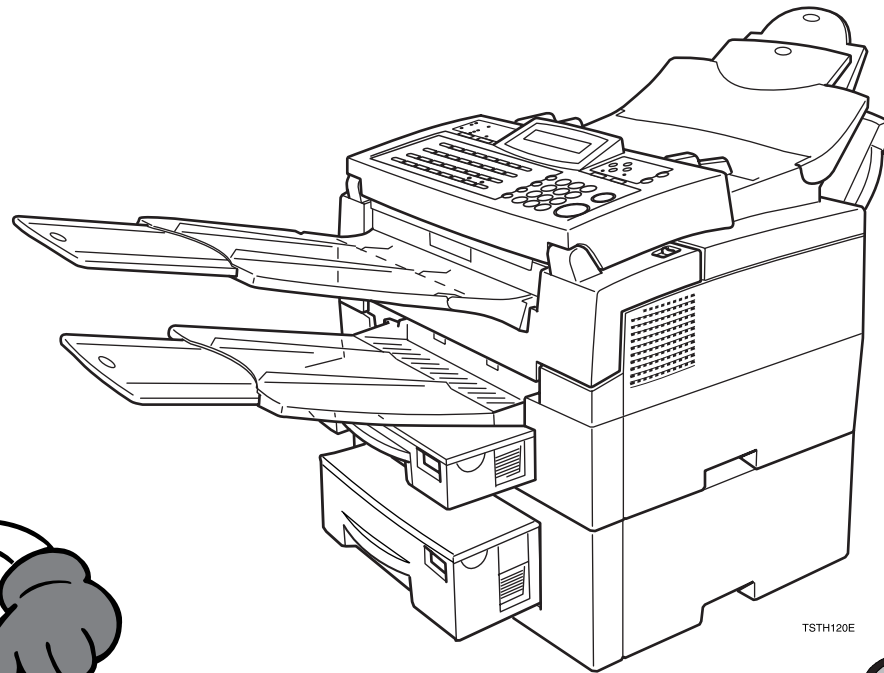

TSTH120E

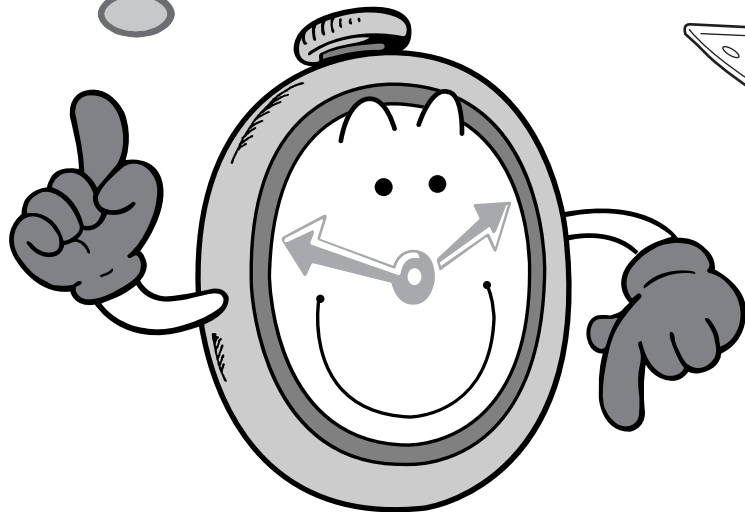

Keep going...

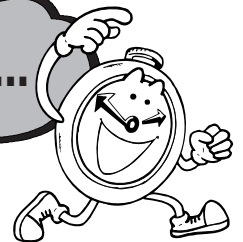

Installing the Toner Cassette

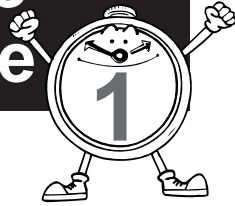

- 1. Remove all tape from the machine.**
Pull the cover release lever towards you and open the top cover.

Note

▼ If you do not pull the lever, only the upper unit will open.

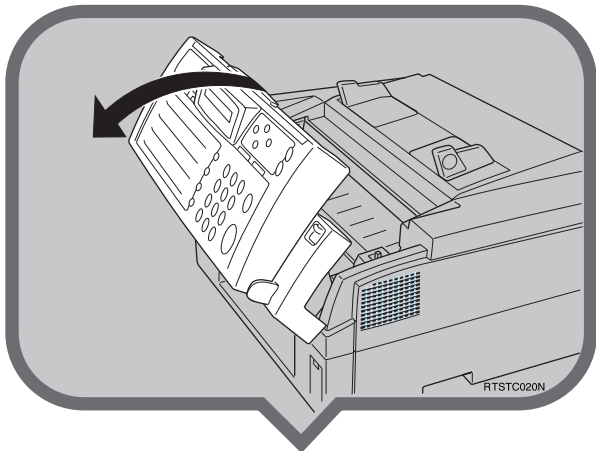
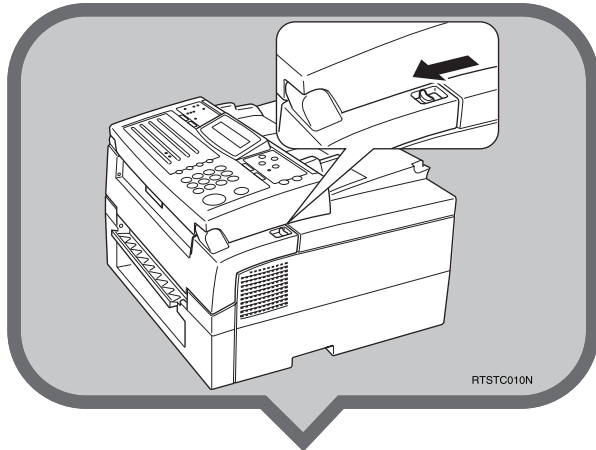

- 2. Prepare the toner cassette.**

Important

▼ Do not touch the green drum.

1. Remove the toner cassette from its bag.
2. Hold the cassette level horizontally and shake it gently from side to side a few times.

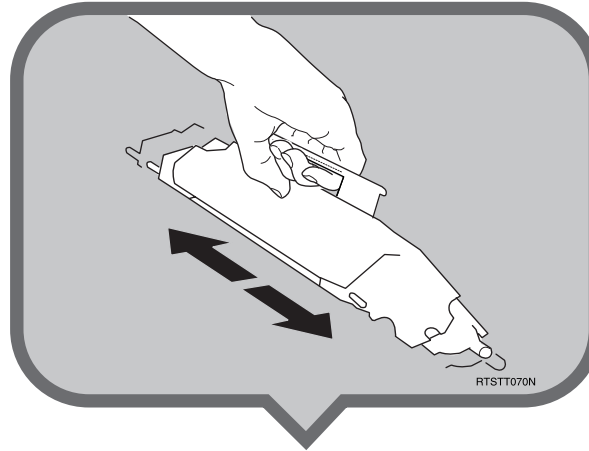

- 3. Hold the cassette as shown and rest it in the machine. Make sure it fits in the slots provided on either side.**

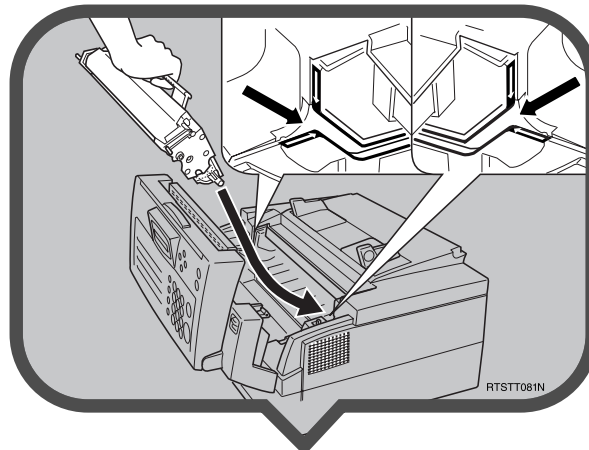

- 4. Press down on the cassette until it locks into place.**

Note

▼ If you do not push the cassette right in, the cover will not close.

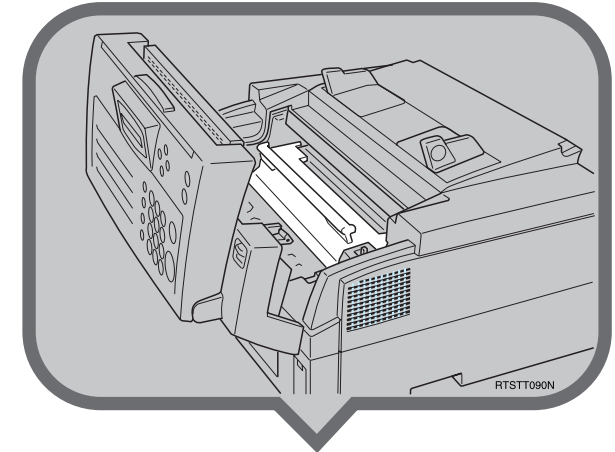

- 5. Close the top cover.**

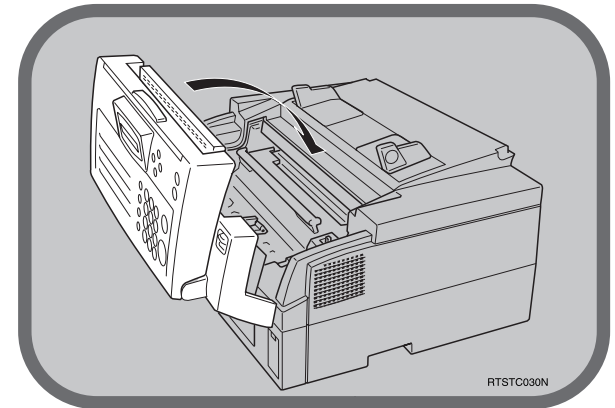

Keep going...



Installing the Main Paper Cassette



1. Unpack the cassette.
2. Peel off the 3 pieces of tape from the cassette cover.
3. Raise the cassette cover.

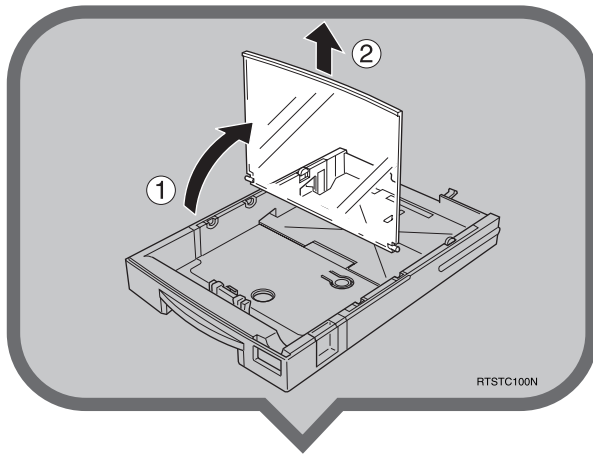

4. If necessary, adjust the paper size.

Note

▼ To change the paper size in the cassette, see “Changing the Paper Size in the Main Cassette” in the fax manual.

5. Set the paper then lower the cassette cover.

Note

▼ The frosted side of the cover must be face up when closed.

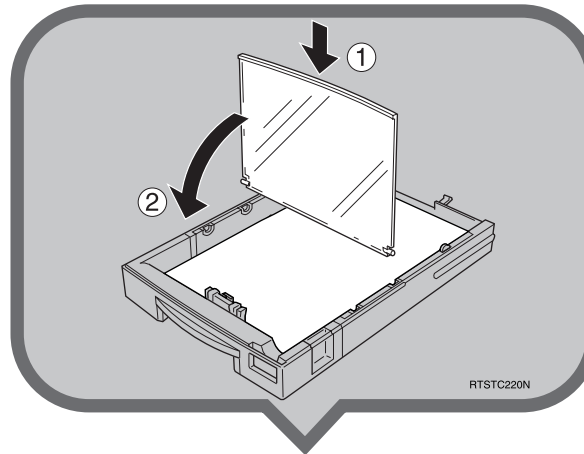

6. Install the cassette. Push it in firmly until it locks into place.

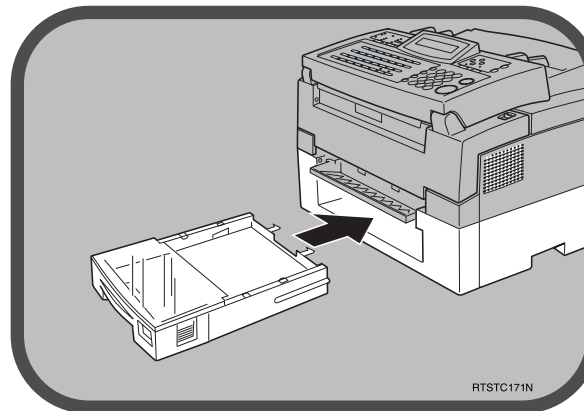

Attaching the Quick Dial Sheet And Operation Panel Sheet



1. Fit the Quick Dial Sheet and Cover Sheet over the Quick Dial keys.

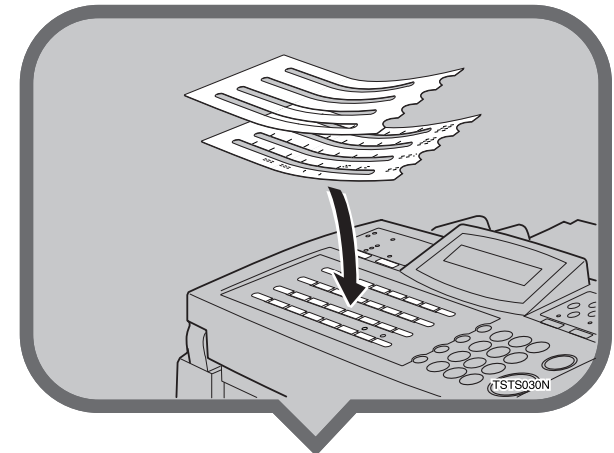

2

2. Fit the 3 Operation Panel Sheets as shown.

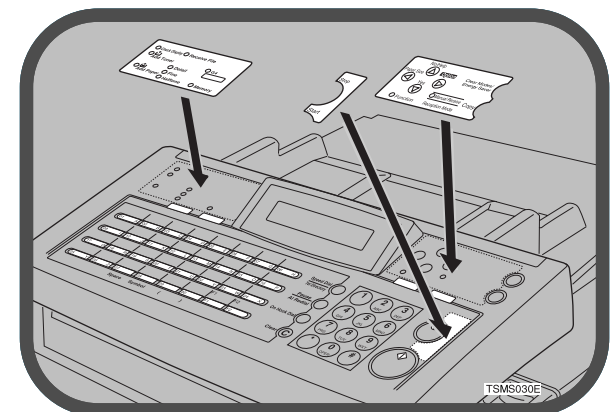

Attaching the Trays And Document Table



1. Attach the Print Delivery Tray. Insert it at an angle so that the tabs fit in the slots provided.

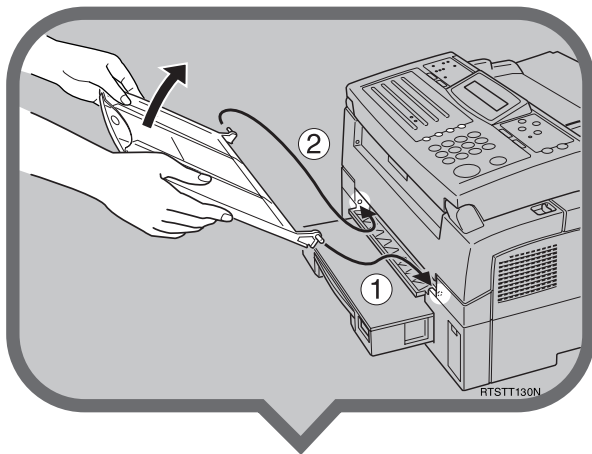

2. Attach the Document Delivery Tray.

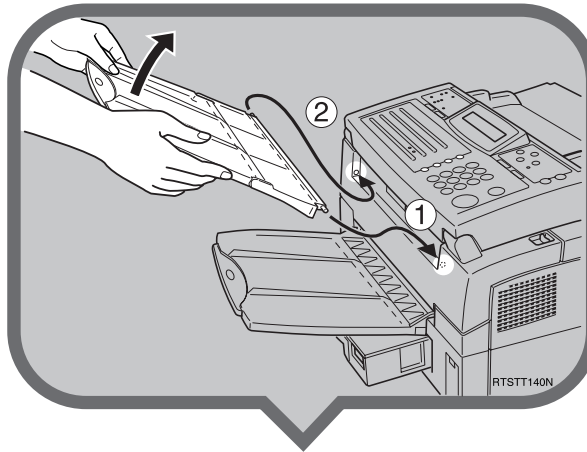

3. Attach the Document Table.

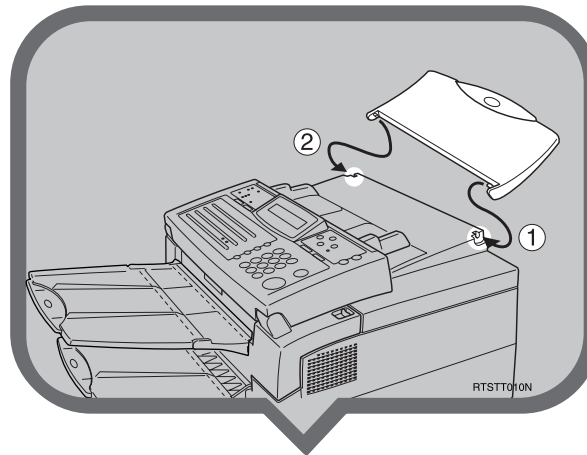

4. If necessary, pull out the extensions on the Document Table and trays.

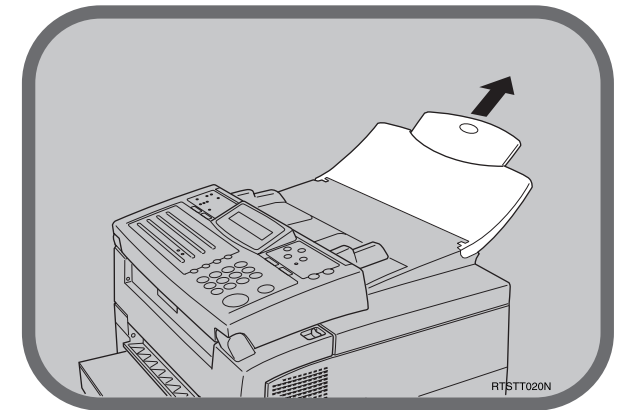
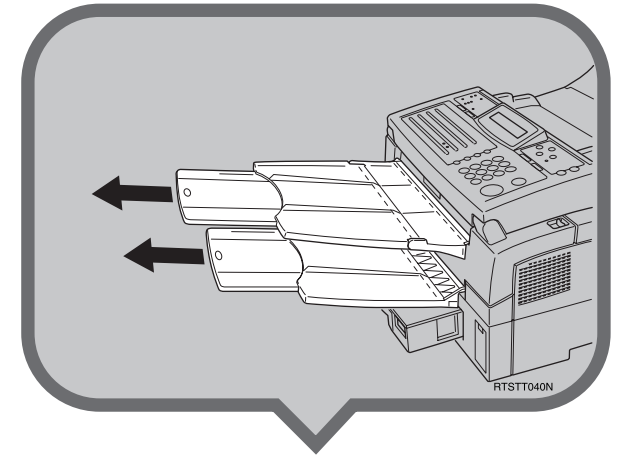

Connecting up to the Telephone Line



There are two similar sockets located at the rear of the machine:

TEL1: For the external telephone
LINE: Telephone line connection

1. Insert the line cable into the socket labeled "LINE".

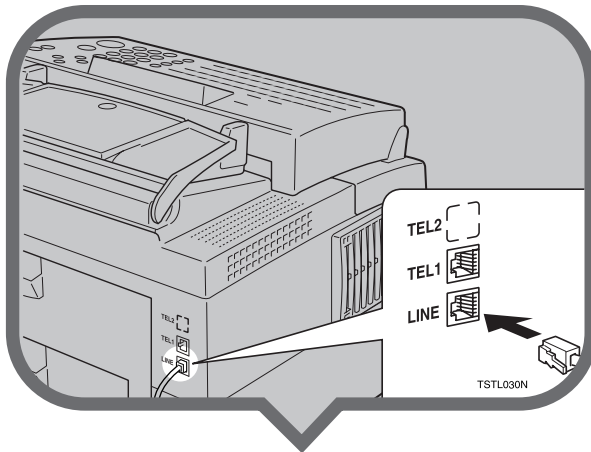

2. Connect the other end to your telephone line.

Connecting the Power and Switching on

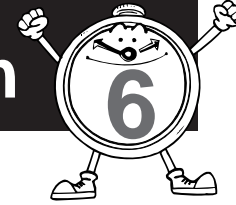

1. Insert the power cable into the socket located at the rear of the machine.

2. Plug in the cable to the mains.

Warning

- ▼ Power requirements : 220-240V, 50/60Hz
- ▼ Insert the power plug securely into the wall socket.
- ▼ Make sure that the wall outlet is near the machine and readily accessible.
- ▼ Do not connect other equipment to the same socket.

3. Turn the power switch on.

Keep going...



Initial Settings & Adjustments



Before using the machine, please adjust the following settings:

- G3 Own Number
- RTI (Remote Terminal Identification), TTI (Transmitter Terminal Identification), and CSI (Called Station Identification)
- Phone Line Type
- Date & Time

To enter letters, use the A-Z keys (Quick Dial 01-26). To enter a space, press Quick Dial 27. To enter Symbols, press Quick Dial 28. To enter digits, use the ten key pad.

5

1. Press the [Function] key and [6], enter the access code [2][2][2][2], then enter [6][1].

```
INITIAL MODE Y/NEXT ►
61 INITIAL SET
```

2. Press the [Yes] key.

```
Y/NEXT ►
SET G3 OWN NUMBER
```

3. Press the [Yes] key again.

```
G3 OWN NO.          KPAD
■■■■■■■■■■■■■■■■■■■■
```

4. Enter your phone number.

Note

▼The format of the number is normally as follows: International Dial Prefix, Your Country Code, Your Area Code, then **you must add a Pause**, followed by your telephone number. Check the International Dialing Prefix and the Country Code with your local telecommunications operator. The example shown is for the USA; the codes to add are 011 and 1.

```
G3 OWN NO.  KPAD/Y/N
0111212-5551234 ■
```

5. Press the [Yes] key.

“PROGRAMMED” will flash on the display and you’ll get the display.

```
Y/NEXT ►
SET CONFIDENTIAL ID
```

6. Press the ► key.

```
Y/NEXT ►
SET RTI
```

7. Press the [Yes] key.

```
RTI          ABC
■■■■■■■■■■■■■■■■■■■■
```

8. Enter your office, company, or personal name, or any other appropriate identification.

```
RTI          ABC Y/N
XYZ COMPANY■■■■■■■■■■
```

9. Press the [Yes] key.

“PROGRAMMED” will flash on the display.

```
Y/NEXT ►
SET TTI
```

10. Press the [Yes] key.

```
TTI          CHANGE? Y/N
XYZ COMPANY
```

11. Press the [No] key to keep the TTI as it is.

```
Y/NEXT ►
SET CSI
```

12. Press the [Yes] key.

```
CSI          KPAD
■■■■■■■■■■■■■■■■■■■■
```

13. Enter your phone number including the country and area codes (but no pauses).

Note

▼This should be the same as your fax number.

```
CSI          KPAD/Y/N
12125551234■■■■■■■■■■
```

14. Press the [Yes] key then the [Function] key. “PROGRAMMED” will flash on the display.

```
READY          100% 10:00
SET DOC. OR DIAL NO.
```



Setting the Phone Line

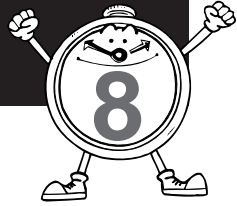

1. Press the [Function] key and [6], enter the access code [2][2][2][2], then enter [6][2].

```
INITIAL MODE  Y/NEXT▶  
62 SELECT FUNCTION
```

2. Press the [Yes] key.

```
SELECT LINE  Y/NEXT▶
```

3. Press the [Yes] key again.

```
SELECT LINE  Y/◀▶  
▶TT  PD
```

4. Press ◀ and ▶ to set your machine for a tone dial line (TT) or a pulse dial line (PD).

Note

▼ If the appropriate line type is selected, you don't need to change the setting.

```
SELECT LINE  Y/◀▶  
▶TT  PD
```

5. Press the [Yes] key then the [Function] key. "PROGRAMMED" will flash on the display.

```
READY 100% 10:00  
SET DOC. OR DIAL NO.
```

Setting the Date & Time

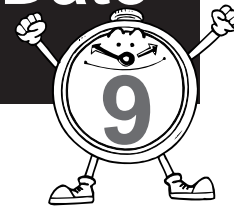

1. Press the [Function] key and [6], enter the access code [2][2][2][2], then enter [9][1].

```
ADJUSTMENT  Y/NEXT▶  
91 ADJUST CLOCK
```

2. Press the [Yes] key.

A date and time will appear.

```
SAT  KPAD/Y  
24 JUL 1999  01:35
```

3. Enter the date on the ten key pad, e.g. [3][0].

```
FRI  */#/Y  
30 JUL 1999  01:35
```

4. Change the month using * or # (* to scroll forward, or # to scroll backward) on the ten key pad, then press ▶ to move the cursor.

```
MON  KPAD/Y  
30 AUG 1999  01:35
```

5. Enter the year and time with the ten key pad, e.g. [9][9][1][0][2][5].

```
MON  KPAD/Y  
30 AUG 1999  10:25
```

6. Press the [Yes] key then the [Function] key. "PROGRAMMED" will flash on the display.

```
READY 100% 10:25  
SET DOC. OR DIAL NO.
```

Changing the Paper Size Settings

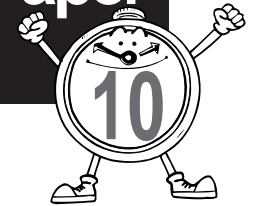

When you change the paper size loaded in the main cassette, optional second cassette or optional Multi-purpose Feeder, you need to change the paper size settings.

1. Press the [Function] key and [3][7], and the [Yes] key.

```
MAIN CASSETTE  Y/◀▶
```

2. Press the ◀ and ▶ keys to select the cassette.

```
2ND CASSETTE  Y/◀▶
```

Note

▼ Only the cassettes installed appear in the display.

3. Press the [Yes] key.

```
2ND PAPER SIZE  Y/◀▶  
A4 (210×297 MM)
```

4. Press the ◀ and ▶ keys to select the paper size in the cassette.

```
2ND PAPER SIZE  Y/◀▶  
LETTER (8.5×11 INCH)
```

5. Press the [Yes] key. "PROGRAMMED" will flash on the display.

```
MULTIPURPOSE FEEDER  Y/N/◀▶
```

6. To program another cassette, repeat 2 to 5.

7. Press the [Yes] key then the [Function] key. "PROGRAMMED" will flash on the display.

```
READY 100% 10:00  
SET DOC. OR DIAL NO.
```

